

# Liberty Pumps®

## LSG202-RE/LSGX202-RE



Available with  
LSG or LSGX-Series  
(2-Stage) Grinders



### **Retro-Fit Systems for E/One® Grinder Packages**

**A Completely  
Assembled Grinder  
Replacement  
Package for E/One®  
GP 200 and GP 2000  
Systems**

#### **Features:**

- Liberty's 2 hp Omnivore Grinder Pump
- Assembled and ready to drop-in-place
- Includes floats, piping and replacement cover
  - Heavy-duty cast iron anti-siphon check valve
- Weatherproof junction box

E/One® is a registered trademark of Environment One Corporation and is not affiliated with Liberty Pumps

innovate. evolve.

# Retro-Fit System for E/One® Grinder Package

## Performance Curves:

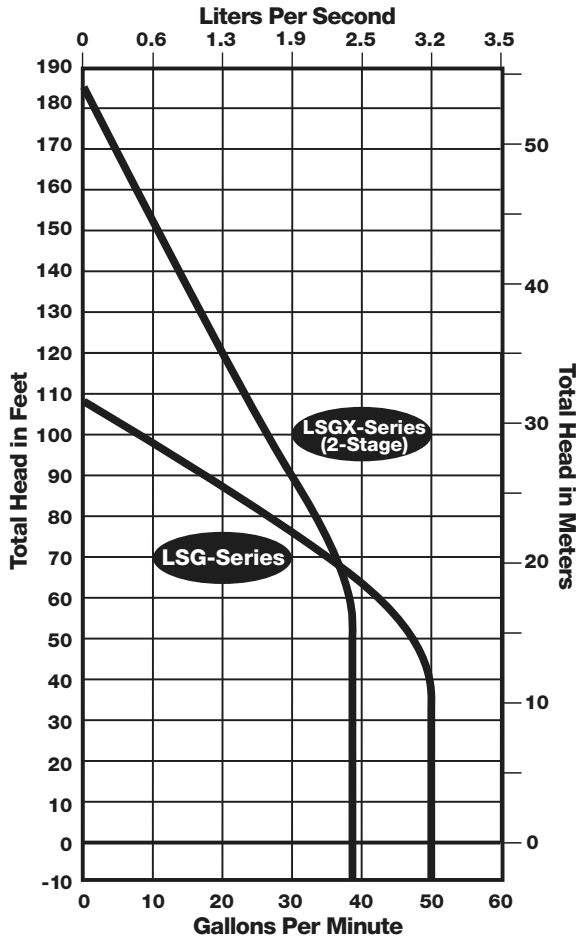

## Dimensional Data

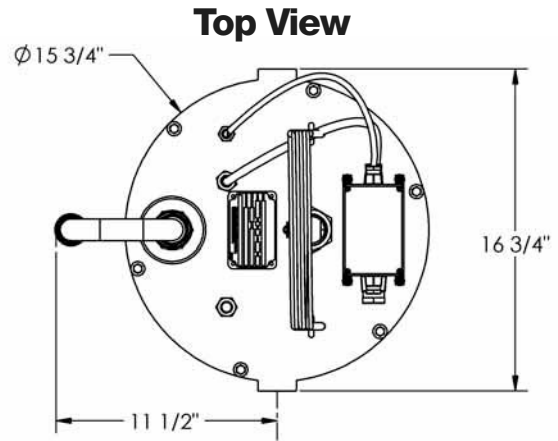

## Side View

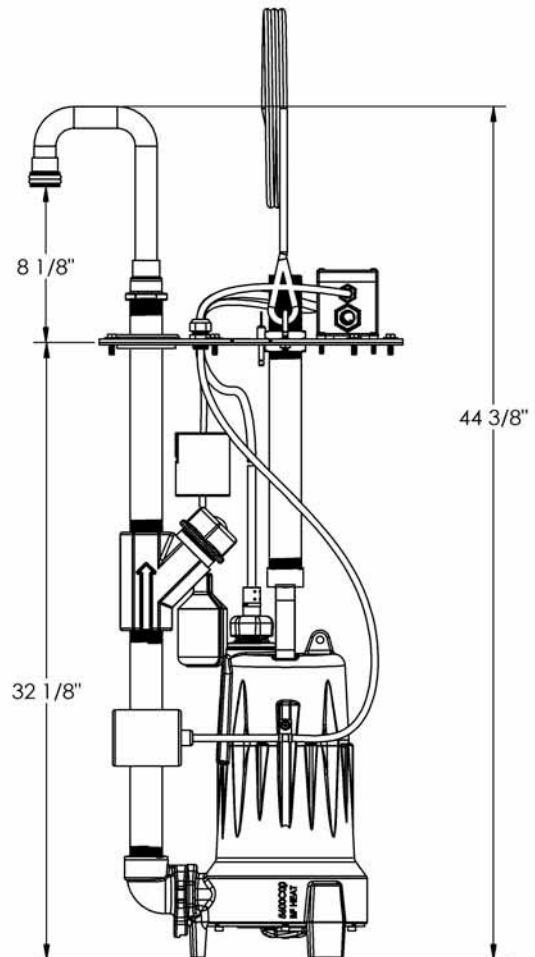

## Models

### LSG202-RE

Single stage grinder model LSG202  
2 hp., 208-230V., 60 Hz. 15 amp, 3450 RPM  
Weight: 123 lbs



Available with  
LSG or LSGX-Series  
(2-Stage) Grinders

### LSGX202-RE

2-stage grinder model LSGX202  
2 hp., 208-230V., 60 Hz. 15 amp, 3450 RPM  
Weight: 129 lbs



See LSG or LSGX series grinder literature for complete pump specification.

Single stage LSG202-RE units may not meet pressure requirements in all applications. Consult factory for proper sizing and technical assistance where forced pressure mains or multiple homes tie into a common waste line.

E/One® is a registered trademark of Environment One Corporation and is not affiliated with Liberty Pumps



Specifications are subject to change without notice.