

Product information presented here reflects conditions at time of publication. Consult factory regarding discrepancies or inconsistencies.

COMPARE THESE FEATURES

- Durable cast construction. ASTM Class 25 cast iron, motor housing cover, and pump housing.
- Engineered plastic base on 270.
- Bronze non-clogging vortex impeller.
- Not affected by materials normally found in drainage and sewage sumps.
- Stainless steel screws, bolts, and handle.
- 20 ft. UL Listed 3-wire neoprene cord and plug.
- Motor - 1 HP, 60 Hz, 3450 RPM, oil-filled, hermetically sealed, automatic reset thermal overload protected.
- Square Ring & Gasket - Neoprene.
- Carbon and ceramic shaft seal.
- Double seal pump available - 4270 Series.
- Cast iron base on 4270.
- Upper sleeve bearing and lower ball bearing running in a bath of oil.
- Passes 2-inch spherical solids.
- 2" NPT Discharge.
- Corrosion resistant powder coated epoxy finish.

Note: The sizing of effluent systems normally requires variable level float(s) controls and properly sized basins to achieve required pumping cycles or dosing timers with nonautomatic pumps.

SIMPLEX AND DUPLEX SYSTEMS AVAILABLE

PACKAGED SYSTEMS AVAILABLE

FEATURES AVAILABLE

- Double Seal Pump in 4270, 115 or 230V, 1Ph, 1HP
- 2" NPT Discharge
- Passes 2" Spherical Solids
- BN and BE pumps available packaged with a Piggyback Variable Level Float Switch

ALL MODELS ARE COMPLETELY SUBMERSIBLE, HERMETICALLY SEALED Watertight - dust tight.

*May be used in those states where codes do not restrict solids size in effluent systems.

270-4270 Series
(For Pump Pre?x Identi?cation see News & Views 0052)

“WASTE-MATE”
SUBMERSIBLE
SEWAGE/*EFFLUENT PUMP
OR DEWATERING PUMP
2" NPT DISCHARGE



Nonautomatic
“270”



Nonautomatic
“4270”
double seal pump





POWDER COATED TOUGH™

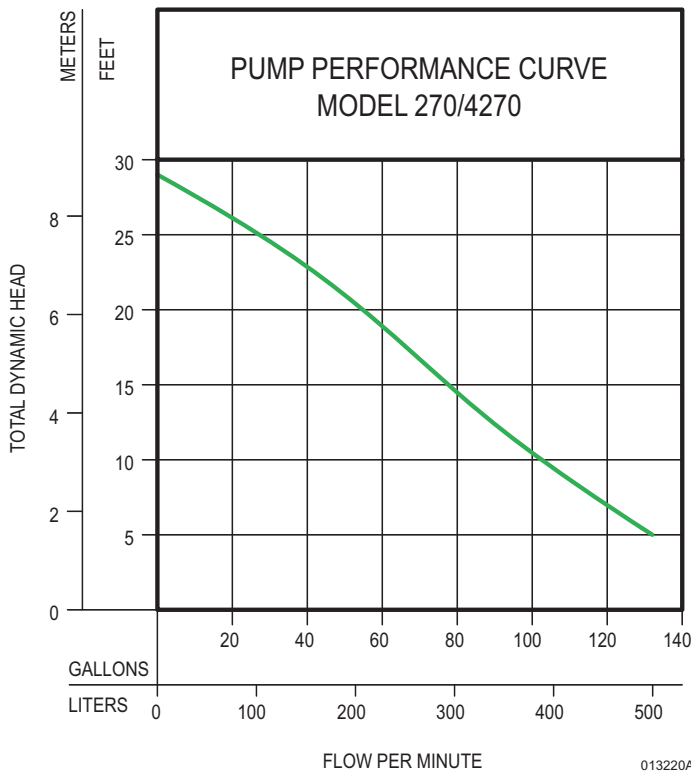

TOTAL DYNAMIC HEAD/FLOW PER MINUTE SEWAGE AND DEWATERING

MODEL		270/4270	
Feet	Meters	Gal.	Liters
5	1.5	132	500
10	3.0	101	382
15	4.6	77	291
20	6.1	56	212
25	7.6	29	110
Shut-off Head:		29 ft.(8.8m)	

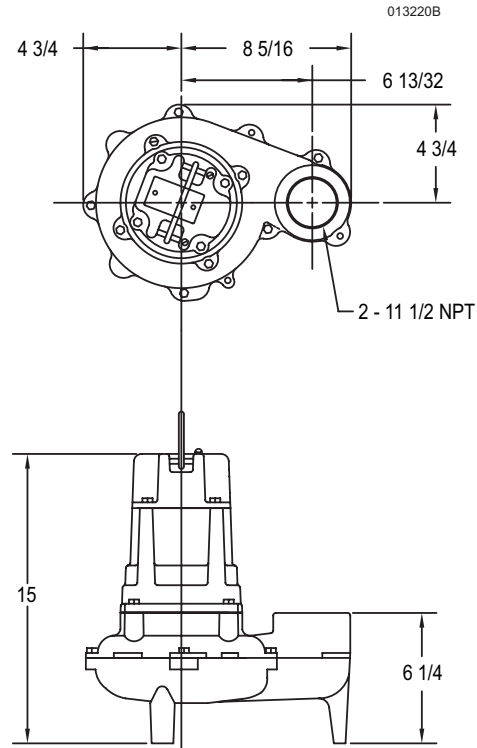
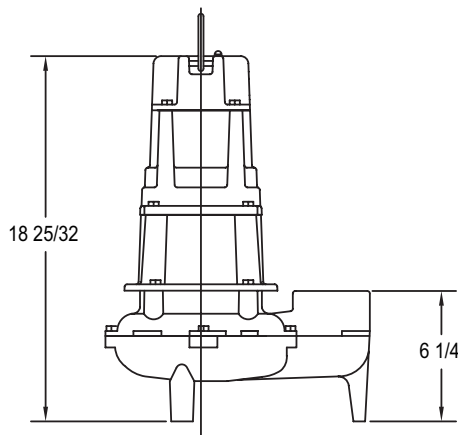

CONSULT FACTORY FOR SPECIAL APPLICATIONS

270/4270 MODELS				Control Selection		
Model	Model	Volts-Ph	Mode	Amps	Simplex	Duplex
N270	N4270	115 1	Non	15.0	1 or 2	3
E270	E4270	230 1	Non	7.5	1 or 2	3

- Electrical alternators for duplex systems available with variable level control switches.
- Minimum recommended basin size (Small load applications) Simplex - 18" x 30" - Duplex - 30" x 30".

Standard All Models -

270 - Weight 49 lbs. 1 HP.
4270 - Weight 73 lbs. 1 HP.

- High water alarms available.
- Mechanical alternators available for duplex systems.

Caution: Maximum temperature of sewage or dewatering must be limited to 130°F (54°C). For over 130°F (54°C) special quotation required.

SELECTION GUIDE

1. For automatic use single piggyback variable level float switch or double piggyback variable level float switch. Refer to FM0477.
2. See FM1228 for correct model of simplex control panel.
3. See FM0712 for correct model of duplex control panel.

For information on additional Zoeller products refer to catalog on Simplex Panels, FM1596; Piggyback Variable Level Switches, FM0477; Electrical Alternator, FM0486; Mechanical Alternator, FM0495; Sump/Sewage Basins, FM0487; Single Phase Alarm Systems, FM0732; Watertight Junctions Boxes, FM1597; and Disconnect & Rail Systems, FM0787.

CAUTION

All installation of controls, protection devices and wiring should be done by a qualified licensed electrician. All electrical and safety codes should be followed including the most recent National Electric Code (NEC) and the Occupational Safety and Health Act (OSHA).

RESERVE POWERED DESIGN

For unusual conditions a reserve safety factor is engineered into the design of every Zoeller pump.