

WHIRLWIND™ STA-SERIES LINEAR AIR PUMPS

WWW.WHIRLWINDAIRPUMPS.COM



2-YEAR WARRANTY

Whirlwind™ Linear Air Pumps are a superior choice for applications that require reliable aeration including septic tanks, decorative ponds, hydroponic & aquaponic systems.

The quiet and energy efficient Whirlwind is a durable and reliable pump for unprotected outdoor use.

Whirlwind air pumps are designed superior to other brand name aerators on the market today.

Models



STA40: 1.7 CFM at 1.9 PSI
STA60N: 2.33 CFM at 2.18 PSI
STA80N: 2.83 CFM at 2.18 PSI
STA100N: 3.71 CFM at 2.6 PSI



STA80AL: 2.83 CFM at 2.18 PSI
Features low pressure alarm.

Order/Questions : 800-778-1540

Septic Tank Parts



Hose and clips included

Hose bib for low pressure alarm connection. (Models: STA60N, 80N & STA100N)

WHIRLWINDTM STA-SERIES LINEAR AIR PUMPS

WhirlwindTM Linear Air Pumps are built for long life in the field. The anti-vibration rubber foot pads provide stability and help reduce noise for quieter pump operation. Designed for easy maintenance. Whirlwind pumps do not require lubrication and the top pump lid with hand adjusted knob provides easy access to the filter compartment and included filter pad for easy inspection and replacement without the need for any tools.

Features

- Easy to Install
- Quiet operation
- Light and compact
- Inside threaded outlet port
- 6-foot power cord

Motor Specifications

Voltage, Freq	120V, 60Hz / 240V, 60Hz
STA40	0.82 Amp / 0.42 Amp
STA60N	1.17 Amp / 0.66 Amp
STA80N/STA80AL	1.70 Amp / 0.80 Amp
STA100N	2.54 Amp / 1.30 Amp

Unit Dimensions

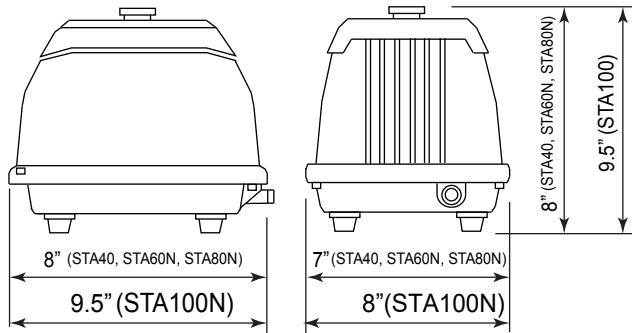

Models STA40, STA60N, STA80N, STA100N

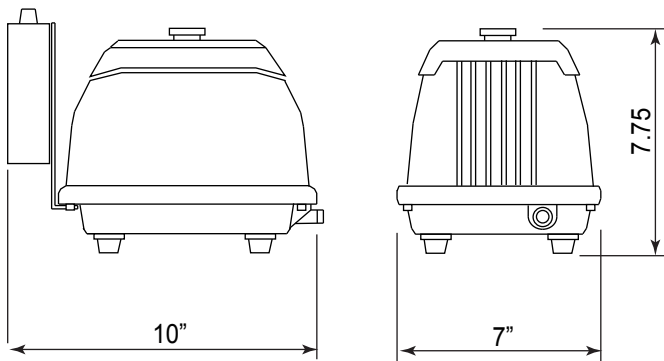

Model STA80AL

Specifications

	STA40	STA60N	STA80N	STA100	STA80AL
CFM	1.7	2.33	2.83	3.71	2.83
PSI	1.9	2.18	2.18	2.6	2.18
Tank Size	500 gpm, 40 L/min	500 gpm, 60 L/min	750 gpm, 80 L/min	1000 gpm, 100 L/min	750 gpm, 80 L/min
Hose Bib		•	•		
Oversized Diaphragms			•	•	•
Thicker Shuttle			•	•	•
Integrated Alarm					•
Dimensions	7" x 8" x 8"	7" x 8" x 8"	7" x 8" x 8"	8" x 9.5" x 9.5"	10" x 7" x 7.75"
Weight	12.5 lbs.	14.7 lbs.	15.2 lbs.	18.3 lbs.	16 lbs.

Septic Tank Parts reserves the right under its product improvement policy to change construction or design detail without obligation regarding previous models and to furnish equipment when so altered without reference to illustrations or specifications used here.