

MAXAIR500™ SUBMERSIBLE AERATORS

WWW.MAXAIR500.COM



2-YEAR WARRANTY

The MAXAIR500™ Submersible Aerator is a superior choice for new installations or upgrading an existing submersible aerator.

The MAXAIR500 has durable corrosion resistant stainless steel legs with heavy duty rubber feet for solid stability in the tank.

The continuous duty maintenance free motor of the MAXAIR500 is fully enclosed in a stainless steel and powder coated outer shell.

Features

- Low rpm, high torque motor fully enclosed continuous duty
- Thermo overload protected
- Stainless steel motor enclosure & legs
- 15-foot power cord
- 1/2" air hose inlet (NPT Female)

The MAXAIR500 submersible aerator is a compatible replacement for the Multi-Flo* aerator manufactured to meet or exceed industry standards on performance and reliability.

Also available
MAX Filters™

(30-Pack)
Complete set of
filter socks

Used in a
Multi-Flo* tank



The MAXAIR500 Submersible Aerator has been independently tested for performance in original manufacturer's tanks and proven to meet or exceed the oxygen transfer rates of original manufacturer's aerator units.



Order/Questions : 800-536-5564

Septic Services, INC.

MAXAIR500™ SUBMERSIBLE AERATOR

The industrial grade factory built MAXAIR500™ aerator has been engineered to meet or exceed industry standards and has been put through rigorous testing in the lab and field to ensure that the MAXAIR500 will provide years of dependable service.

Features

- Air hose inlet: 1/2" I.D. FNPT
- Low rpm, high torque fully enclosed continuous duty motor
- Stainless steel motor enclosure & legs with heavy duty rubber feet
- Integrated high impact plastic handle
- Powder coated outer shell
- 15-foot power cord
- 15-foot nylon pull rope

Specifications

Amps	2.7
Volts	115 single phase Thermal protected
RPM	1725
Air Hose Inlet	1/2" I.D. FNPT
Unit Dims	25" x 9.5"
Unit Wt	32 lbs.

Unit Dimensions

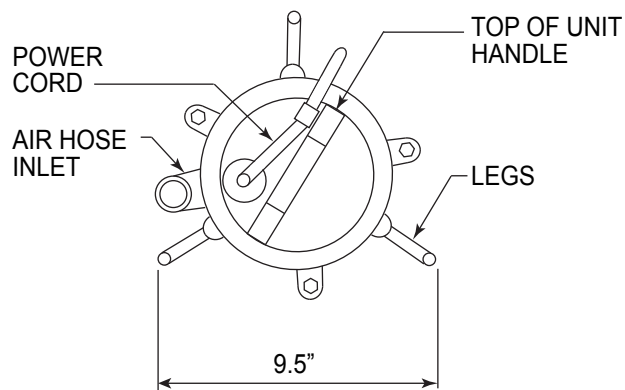

TOP VIEW DIAGRAM

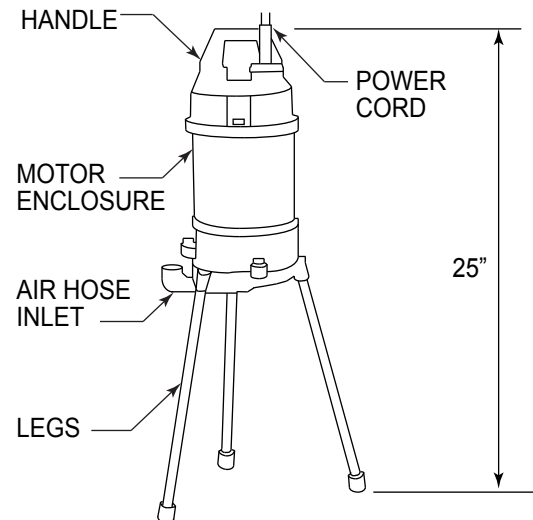

SIDE VIEW DIAGRAM

Submersible Aerator Advantages

Submersible aerators have a number of advantages over other types of aerators.

- ☑ Higher oxygen transfer rate.
- ☑ Use the same or less electricity of other type of aerators.
- ☑ Submersible aerators sit down in the tank and so are better equipped to handle extreme weather conditions.
- ☑ Can be used in 2-compartment tanks.



*All original manufacturer's names, drawings, and part numbers are used for identification purposes only and we are in no way implying that any of our products are original equipment parts. Multi-flo is a registered trademark of Consolidated Treatment Systems, Inc.

Septic Services, Inc. reserves the right under its product improvement policy to change construction or design detail without obligation regarding previous models and to furnish equipment when so altered without reference to illustrations or specifications used here.

Septic Services, Inc. • 7059 Hwy 47 (shipping) P.O. Box 632 (mail) • Union, Missouri 63084 • Tel: 800-536-5564 Fax 636-583-6432 • sales@septicsserv.com

Copyright © Septic Services, Inc. 2016
All rights reserved.

www.septicsserv.com/store • www.maxair500.com